

Output current is 5mA per channel.

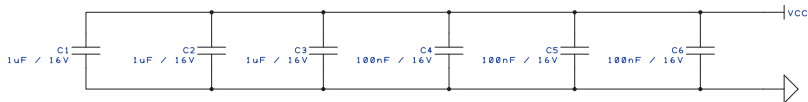

PROJECT: Engduino V3.1	
DRAWING TITLE: LED driver - LEDs	
DRAWN BY: Engduino Team	
REVISION: 1.0	
SHEET: 2 OF 2	STATUS: http://www.engduino.org
DATE: 16/1/2015	DESIGNSPARK PCB available for FREE at www.DesignSpark.com/PCB

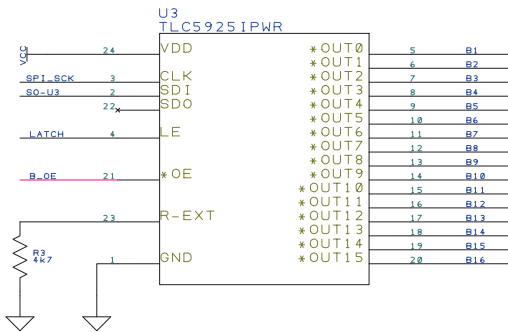
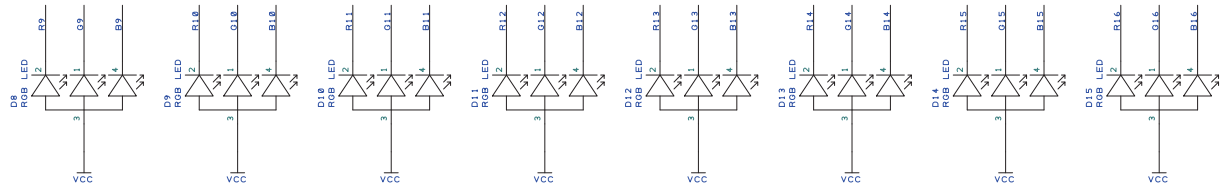
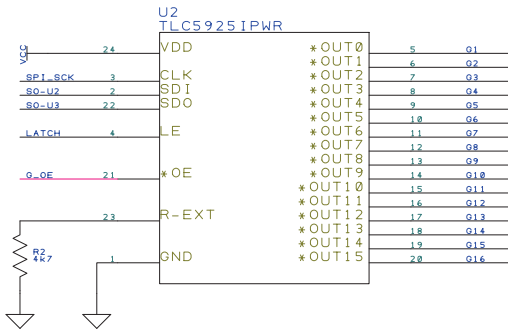
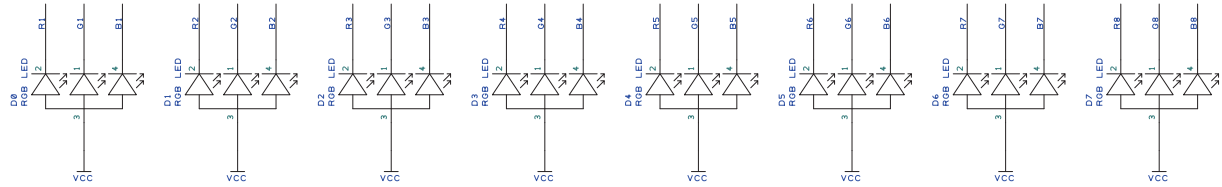
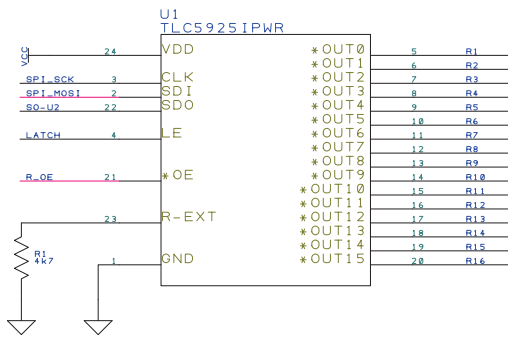